



(11) **EP 1 710 372 B1**

(12) **EUROPEAN PATENT SPECIFICATION**

(45) Date of publication and mention of the grant of the patent:
22.04.2009 Bulletin 2009/17

(51) Int Cl.:
B21D 11/14 (2006.01) **E04C 5/03** (2006.01)
B21F 7/00 (2006.01) **E04B 1/41** (2006.01)
E04G 23/02 (2006.01)

(21) Application number: **06015877.1**

(22) Date of filing: **10.08.2001**

(54) **Helical connector**

Spiralförmiges Verbindungselement

Connecteur hélicoïdal

(84) Designated Contracting States:
AT BE CH CY DE DK ES FI FR GB GR IE IT LI LU MC NL PT SE TR

(30) Priority: **12.08.2000 GB 0019786**

(43) Date of publication of application:
11.10.2006 Bulletin 2006/41

(62) Document number(s) of the earlier application(s) in accordance with Art. 76 EPC:
01955457.5 / 1 307 303

(73) Proprietor: **Ollis, William Henry**
Buckinghamshire HP17 8AH (GB)

(72) Inventor: **Ollis, William Henry**
Buckinghamshire HP17 8AH (GB)

(74) Representative: **Raynor, Simon Mark et al**
Urquhart-Dykes & Lord LLP
Midsummer House
413 Midsummer Boulevard
Central Milton Keynes MK9 3BN (GB)

(56) References cited:
EP-A- 0 171 250 **EP-A- 0 494 099**
GB-A- 2 262 560 **US-A- 4 325 657**

EP 1 710 372 B1

Note: Within nine months of the publication of the mention of the grant of the European patent in the European Patent Bulletin, any person may give notice to the European Patent Office of opposition to that patent, in accordance with the Implementing Regulations. Notice of opposition shall not be deemed to have been filed until the opposition fee has been paid. (Art. 99(1) European Patent Convention).

Description

[0001] The present invention relates to connecting devices, which could for example take the form of nails, fasteners, ties or reinforcements. In particular but not exclusively, the application concerns torsional deformation arrangements through which lengths of metal, having two or three major radial fins projecting from a central core, are pushed to give them helical configurations; so that they can provide a screw-like grip in a wide variety of softer or lower density materials used by construction industries, when driven axially into or embedded into them. The radially finned helical products envisaged are similar to ones described in EP 0494099, GB2262560 EP 0171250 and may be used to serve as ties, reinforcements, fixings and/or fasteners. Grooved rollers or other means can be used to push wires, rods or extrusions through helical deformation arrangements to form the connecting devices.

[0002] At present, such wires are given a helical configuration by gripping opposite ends of long lengths of wire and then spinning one end whilst the other is held stationary. It has been found that present methods of providing helical configurations are unreliable and limiting in a number of important respects. The helical pitch is liable to vary along a length of wire being twisted, to an unacceptable extent. Published tolerances on such wires are as much as plus or minus 2mm on a 40mm pitch, creating a discrepancy of up to 10%. Variation occurs wherever there is a slight change in metal or geometric characteristics, which inevitably happens at the ends. This is because the ends have to be gripped before any twisting takes place, for a distance sufficient for the torsional forces to be taken at the ends. Such ends do not conform and have to be cut away as waste material. Another problem is that, when a long length is twisted between end grips, its overall length is progressively reduced as it is twisted and it will pull out of its end gripping device unless this device can slide in a spring loaded fashion.

[0003] The reasons why it is functionally essential for a helical finned wire to have an accurate constant helical pitch throughout its operational length is explained in detail later with reference to drawings. In essence, if it does not, the grip provided will be largely ineffective when the connecting device is driven into a relatively weak building material such as aerated concrete, because of the destructive passage of helical fins of varying pitches progressing through it. In addition, the resistance induced in driving a helix with a non-uniform pitch, into hard materials, will be greatly increased.

[0004] US 4325657 discloses a connector having a helical body and a retaining head.

[0005] According to one aspect of the invention there is provided a connector according to claim 1.

[0006] Advantageously, the accuracy of pitch varies by no more than 0.5% from any given pitch along the axis of the device and the connector includes a load spreading

pressed clip or wash-like retaining head for securing and clamping construction layers together.

[0007] The axial core material has a cross section comprising two-fifths or less of the circumscribed cross sectional area of the connector.

[0008] The connector may include a rear end portion having projecting tabs of material upon the fin material ends.

[0009] The connector includes two or three major fins extending from the central core.

[0010] The connector may comprise an open helix. The helical pitch may include at least one full 360° rotation within an axial distance of five and a half circumscribed profile diameters.

[0011] The device comprises a wire body.

[0012] The device may include a front end portion having a profile providing a swept angle of between 20° and 40° inclusive.

[0013] The device may include a front end portion having a flat nose end with an area corresponding to between 90% and 40% of the common axial core cross section.

[0014] The connector device has common axial core material and two or three major helical fins, flanges or ridges that extend outwards from the core, and the connector can be manufactured using an elongate preform member, that is forced in the axial direction of its core through a helical deformation arrangement in order to deform the preform member helically, such force being carried through the common axial core material the cross sectional area of which is less than 40% of the circumscribed cross-sectional area of the connector.

[0015] Advantageously, the helical deformation arrangement has accelerating helical compound angles to twist the preform member in such a way that it becomes helical. Preferably such an arrangement has a substantially straight entry portion.

[0016] Advantageously, the preform member has weakened zones at predetermined intervals in order that lengths may be snapped off after twisting to produce a plurality of fixing devices. Preferably, the weakened zones are shaped so that when it is snapped, each connecting device has at least one pointed end. Helix forming arrangements can be used satisfactorily in conjunction with some other manufacturing techniques, for example, immediately after metal comprising the preform member is extruded through an extrusion die in a molten or semi-plastic state. Helical deformation arrangements advantageously concentrate working heat energy within, a relatively short working zone utilising a warming effect, making the material more malleable. It is important that the helical deformation arrangement has a straight entry passage, for a radially finned wire body to enter, reducing significant resistance for a distance sufficient to provide large enough torsional reaction surfaces, ensuring the fin material is not sheared off. It is important that the exit has a helical pitch corresponding with the required pitch of the end products, for a sufficient distance to provide sufficiently high surface area to induce torsional stresses

beyond elastic limits.

[0017] A preferred version of the invention involves the use of a helical deformation arrangement that provides a continuous passage in which there is a helical acceleration. The pitch accelerates smoothly from zero to the helical compound angle required at the far end. It will be appreciated that surfaces necessary to exert active and reactive forces along the length of the metal section will be available as and where needed along the whole length of the arrangement. With such deformation arrangements a leading end of preform member can be pushed straight into and through such an arrangement. For similar reasons, it is possible to continuously push through such a member, which has already been stamped at intervals to provide lengths of helical material with shaped leading and trailing ends that can be subsequently snapped apart for end use. It will be appreciated that, after a finned material has already been given a helical shape the profiling of the lead or trailing end using a stamping or shearing die will be geometrically much more complicated, in light of various complex compound angles. It will be appreciated that the helical pitch would need to be absolutely regular to enable pre-twisted material to feed into and register efficiently with such intricate stamping die geometry.

[0018] The novel method of forming a point profile onto connecting device sections in the preform member, prior to twisting, achieves numerous benefits. The benefits are threefold. Primarily geometric profiles of distinctive form and advantage can now be produced. Secondly the form of the stamping tools can be straight profiled, simply set and resharpened. Finally the tool wear life is prolonged when working upon lesser worked material.

[0019] It must also be appreciated that any slight irregularities in the profile prior to helical deformation will be removed as the sections are subsequently forced through the precise helical deflection path.

[0020] The helical deformation arrangement will transform the preform section into a helical section with an absolutely true helical path accurate at any one given point to plus or minus half of one percent when measured along the axial length. Where such sections are conventionally twisted (into an imperfect helix), the driven interlock path will inevitably be inaccurate and widened in use, and the mating of the connection slackened. Such slackening effect may also be compounded, during the forming of the lead in point profile, by flash from grinding processes upon the swept fin edges or by post-stamping deformation upon the pointed leading end, or possibly both.

[0021] Another two features of such a pre-stamping arrangement are that accurate flat noses can be forged in, and that trailing ends can be given profiles, which can serve as a clamping head. The flattened or blunt nose of the point profile serves the purpose of avoiding splitting and compaction failure of materials into which they are driven. It is common practice to blunt the end of a nail before driving it into a slender timber element to avoid

splitting. Alternatively, when driving a spike like point profile into timber, the tendency is for the wood fibres to slither apart longitudinally on either side of the shaft. This tends to induce penetrative spreading forces along the length of a split.

[0022] A correct flattening off of the spike-like profile will cause a localised compressive cut through the fibres reducing their tendency to induce splitting resultants.

[0023] With non-fibrous materials such as aerated concrete made up of microscopic air bubbles, a spike like point profile creates an enlarged compaction wave of failed material ahead of itself. On the other hand the point profile of any driven fixing, fastening or connector must have a proportion of lead in taper angle as it would otherwise wander if left as a flat cut.

[0024] Nails, screws and other fastenings that have stamped points have a spike like profile so they easily separate from one another in production. The method of pre-stamping a profile with a deliberate neck for continual feed, means that a functional flat nose is provided when separation forces are induced across the neck in the subsequent torsional action of helical deformation.

[0025] With conventional twisting, the accuracy and tightness of pitch is far slacker than with contained helical deformation arrangements. Those sections that would twist reasonably in the conventional manner with a degree of consistency would have a full common core cross-sectional area of half the entire circumscribed area. This balance is required, as metals commonly have stress and strain behavioural characteristics that are the same in tension as in compression. If the compressed core material falls to within 40% of the entire circumscribed area, there is a strong tendency for the section to become axially distorted as the common core material is insufficient to restrain the stresses induced by the elongate helical path of the radially projecting material.

[0026] With the preferred arrangements a tightness of pitch of one full twist rotation axially within a distance of five and a half circumscribed diameters or less can be achieved. With any twisting action there is a balance of stresses and strains that has to be contained to avoid axial failure upon the core. The outer extremities in the form of either fins or flanges are strained into a tensile mode as they are induced to follow an elongated helical path. These tensile forces are resisted by the inner portion of the section, which is capable of taking such compressive resultants when contained and restrained from axial distortion within an enclosed deformation arrangement.

[0027] It should be appreciated that the swept point angle outwardly tapering from the core would follow upon a helical compound angle and would not be of a straight cut. It should also be appreciated that the forming of a single deformation arrangement, with an internal helical configuration, involves difficulties in forming surfaces with complex helical compound curvatures. However, these difficulties can be overcome by means of extensive investment in broaching tooling and the benefits are suf-

ficient to justify their expense. Another benefit of such helical deformation arrangements is that serrated indents and product markings can be rolled onto the section before deformation, without interfering with the smooth deforming operation.

[0028] EP 150906 managed to achieve the desired tightness of pitch by deforming a tube into helical configurations. The tightness of pitch is also a limiting factor upon GB2107017. However a deformed tube has a low axial strength and limited application. The proposed arrangement resolves these limitations.

[0029] By way of example, embodiments of the invention are now more fully explained and described in terms of various applications, with reference to the following drawings, wherein:

Figures 1A to 1I show typical sections with radial fins suitable for being given helical configuration by means of deformation arrangements and demonstrate torsional failure of sections twisted in the conventional fashion;

Figures 2 and 2A to 2E are side elevations that illustrate and explain the importance of providing helically finned products for use in construction work with helical pitches that are constant throughout, which can be achieved by means of deformation arrangements;

Figures 3A and 3B are side sections that illustrate the adverse effects of driving a helical fixing with an irregular pitch into aerated concrete blockwork in comparison to a helical fixing with a regular pitch;

Figures 4A to 4D show the complex helical compound curvature of a perfect functional swept angle point and the formation of trailing tab ends, in which Fig. 4A is a cross-section, Figs. 4B and 4C are side elevations and Fig. 4D is an isometric view;

Figures 5A to 5D are side elevations that show how helical fixings with regular pitches can conveniently be manufactured with leading and trailing ends having various different profiles for different purposes, by means of a helical deformation arrangement having a pitch which accelerates steadily from zero degrees at the inlet mouth to the pitch required at the exit: a particular example shown is a trailing end with the radial fins extended to form folding over end tabs;

Figures 6A to 6C show the ballistic characteristics and compaction pressure wave effects of different point profiles, in which Figs. 6A and 6B are side elevations, Fig. 6B being at an enlarged scale, and Fig. 6C is a side section;

Figures 7A and 7B show a roller arrangement for rolling indents onto a section prior to helical defor-

mation, in which Fig. 7A is a side elevation and Fig. 7B is a cross-section;

Figures 8A and 8B are cross-sectional views that show the helical deformation tooling set ups and arrangements of torsional radiused bearing surfaces, Figure 8B being at an enlarged scale;

Figure 9 is a side elevation that shows a pointing and parting process for tubular sections;

Figures 10A to 10C show the merits of using a round wire that is not part of the invention that has been deformed into an open helix for reinforcement of masonry walls in both new build and retrospective applications, in which Fig. 10A is a side section, Fig. 10B is an isometric view and Fig. 10C is a cross-section;

Figures 11A and 11B show a triangular section deformed into an open helix, Fig. 11A being a cross-sectional view and Fig. 11B being an isometric view;

Figures 12A and 12B show a round wire form that is not part of the invention being deformed into an open helix, Fig. 12A being a cross-sectional view and Fig. 12B being an isometric view;

Figures 13A and 13B show a conventional reinforcing rod profile a in cross-sectional view and isometric view;

Figure 14 is an isometric section that shows the use of a helical fixing, with trailing end tabs, to secure layers of composite wall materials, in a way which enables a simple load spreading pressed clip or washer-like retaining head.

Figure 15 is a cross-section that shows a bandoleer of collated helical fixings coiled up in a cylindrical container that has an outlet duct so that the fixings can readily be driven by a nailing gun into constructional materials;

Figures 16A and 16B are alternative side-sections, which show how radially finned reinforcement wires or rods, with constant helical pitches, can be used to provide reinforcing cages with rods or wires set at right angles to one another;

Figure 17A is a graphical representation that shows the acceleration path of a typical helical deformation arrangement and the internal increments of angular deflection, and

Figure 17B shows in diagrammatic view how the other two sets of angles related to the longitudinal helical path have to be incorporated within the overall three-

dimensional compound angular arrangement.

[0030] The figures listed above are now explained in detail below:

[0031] Figure 1A is a typical axial cross-section of a preform member comprising a wire which has been rolled through grooved rolls to form two radial fins (2) projecting from a central core (1) outwardly to the notional effective helical circumscribed diameter (35) with the central core (1) fully contained within the notional circumscribed half diameter cylinder (36). Such a wire can conveniently and advantageously be given a constant helical configuration by pushing a length through a helical deformation arrangement in which both active and reactive torsional forces are applied to the projecting fins (2). It will be appreciated that if the wire being processed is in the form of a very long continuous coil, there will be little loss of working time in having to re-load the apparatus. The preform member also includes a pair of stubby ribs (3) that are created by the rolling process.

[0032] Figure 1B is a typical section of perform member comprising of a wire with a central core (1) and three radial fins (2). It could, however, easily comprise of an extrusion of an aluminium alloy or of some other metal suitable for extrusion.

[0033] Figure 1C is a typical section of an aluminium alloy extrusion in which the central core takes the form of a cylindrical tube with a hollow void (43) with nibs (3) projecting into its central void (43).

[0034] Figure 1D is a section with three radial fins (2) similar to that in Figure 1B but the core (1) is provided by the common root material of the fins, such being more convex than normal fins.

[0035] Figure 1E shows a section very similar to Figure 1A with radiused inner faces, rolled between two or four rollers in the same fashion.

[0036] Figure 1F shows a helical section, similar to that in Figure 1B, contained in a helical deformation arrangement (22), showing the concentration of stresses represented by curved lines at the root of the fin (2).

[0037] Figure 1G shows the same section as in Figure 1C, where the helical section is tubular, with the same pattern of concentrated stresses around the root of the fin (2) represented by curved lines, which, if not contained, would cause cylindrical pinching collapse.

[0038] Figure 1H shows the manner in which a helical section, such as that in figure 1F would torsionally fail if twisted freely between two centres while not contained.

[0039] Figure 1I shows the same torsional failure effect that would occur in the same way when applied to a tubular section.

[0040] Figures 2 and 2A to 2D are intended to set the scene for subsequent explanations of the importance and advantages of being able to produce finned helical connectors, having constant helix pitches.

[0041] Figure 2A shows a helical section (4) of a connecting device and alongside this an elevation of a length with equal distances between adjacent radial fins. Such

constant pitches can only reliably be produced by processing preformed material through a helical deformation arrangement (22). Above the elevation drawing of this length of helically transformed wire is shown in Fig. 2 a set of fin tip locus lines (5) that would be imprinted if a length of helical wire, with a constant pitch distance were rolled through 360 degrees across a surface capable of being indented. It will be seen that these locus lines (5) are all straight, parallel and equidistant from one another.

[0042] Figure 2B shows a similar helical section (4) with two fins opposite to one another in which the helix pitch, as signified by the distances between adjacent fins (6), decreases slightly along the length from left to right. As previously explained, lengths of helically finned wire with non-constant helical pitches are liable to arise when long lengths of wire are conventionally twisted by applying torque at their extreme ends. Above this drawing in Fig. 2E is shown a set of fin-tip locus lines (5B) that would be imprinted if a length of helical wire, of a progressively decreasing helical pitch, were rolled through 360 degrees across a surface capable of being indented. It will be seen that these locus lines (5B) are not parallel or equidistant but become progressively closer and steeper from left to right. These particular locus lines are shown with lines of dots. Also included in this part of the drawing is a copy of the fin-tip locus lines (5) applicable to the length of wire with a regular helix pitch as shown in Figure 2A. The spaces between the two sets of fin-tip locus lines (5, 5B) have been hatched to show the accumulating discrepancies between the two sets of lines representing the loss of helical interlock culminating in voids (15) shown later.

[0043] Figure 2C shows two lengths of wire of the type shown in Figure 2A with regular helix pitches nestling closely side by side with one another. If the lower length were to be pushed at its left-hand end (8) towards the right and if the upper length were restrained at its right hand end (9), the intermeshing of the two sets of radial fins would cause the lower length to rotate as it was pushed forwards. Such arrangements for including immediate rotation are very beneficial with helical fixings collated side by side for insertion by nailing guns delivering axial impacts.

[0044] Figure 2D shows a helical fixing with a helical pitch that is irregular side by side with one having a regular pitch. Clearly these cannot intermesh.

[0045] Figure 3A shows a longitudinal section (10) that is drawn through the central plane of a short length of helically finned wire (10) that has a non-constant helix pitch (6), decreasing from left to right, as shown in Fig 2B. It is shown embedded in a block of aerated concrete (12), having been driven, with a hand hammer (13), through a thin piece of softwood (14), such as a skirting board. The front part of the fixing, which first entered the block through the skirting board, will have cut helical passages in the softwood board and the adjacent block material corresponding with the helix pitch at the leading

end of the fixing. This will have caused the fixing to rotate according to this portion of the pitch. As the leading end continues to penetrate further, it will be followed by parts of the fixing with differing pitches and the helical passages will become widened, tending to "strip" the helical threads progressively behind the leading end as driven. The grip of the fixing into the block will become largely ineffective. The voids (15) are caused by the helix's non-conformity. It will be appreciated, in the light of this that if a tensile force is applied the effective resulting reactions will be confined to surfaces provided at the far left-hand end only of the connecting device. If the concentration of stress causes failure and the fixing moves, it is unlikely that any of the helical fins closer to the surface will be able to provide any further resistance in a load-sharing manner, as the deflection restraint will vary with the accuracy of pitch connections.

[0046] Figure 3B shows a similar situation to that in Figure 3A but in this case the helix pitch is constant throughout. It will be seen that the "threads" cut are neat and fully effective throughout, as shown in Fig 2A, additionally enhancing frictional compaction grip.

[0047] Figure 4A shows an end elevation of a precisely true helical swept cut (18) profile. Also shown is the effect of grinding flash (16) away from the true helical cut (18) inducing a slackening of the helical mating path.

[0048] Figure 4B shows a plan view elaborating the swept inclusive angle (18) which will be between 20° and 40° inclusive.

[0049] Figure 4C shows a side elevation of the stamped point profile (24). It will be noted that along the swept leading edge of the fin it follows a curvature trailing away from the core (21) as shown in figure 4A.

[0050] Figure 4D shows, to the left, points stamped onto a preform member prior to helical deformation, as shown to the right. The operation can provide either a flat end to the preceding component as shown by the dotted line on the fins (28) or one with trailing end tabs (25). The neck configuration (21) can be seen more clearly providing a good swept angle point composition upon the more central core-like material.

[0051] Figure 5A shows a cross-section and an elevation of a short length of preformed wire, with two fins projecting from a central core. At a point along the elevation, parts of the section are shown to have been stamped away (20) and part of the core at this point is shown to have been indented (21). At both sides of the position where the stamping takes place, guide blocks (23) need to be provided to locate the wire to stamp it accurately and to stop it from buckling as a result of the pushing forces, normally applied by shaping rollers. The preformed and stamped wire has to be pushed through helical deformation arrangements (22), with an internal void with an accelerating helix configuration.

[0052] Figure 5B shows a diagrammatic side view of a length of preformed wire which has been stamped as described with reference to Figure 5A, being pushed through a helical deformation arrangement (22) compris-

ing a die, in which an internal helical path of compound angles with an accelerating pitch is indicated by dotted lines. At the right hand end of the drawing, a stamped out and indented (20,21) part is shown entering the straight mouth part of the helical deformation arrangement before the helix starts. From there on, the pitch begins and is steadily increased to a maximum at the exit end. Beyond this arrangement is shown a helical deformed version of the stamped and indented part. It will be clearly seen that this now forms an arrow-shaped head (24) a snap-off indented neck point (21) and trailing end tabs (25) of fin material.

[0053] Figure 5C shows a short length of helical fixing ready to be separated for use. The particular usefulness of trailing end fin tabs (25) is explained later with reference to Figure 14.

[0054] Figure 5D shows a differently shaped snap-off neck (26) whereby both ends of a connector have the same chevron profile. Various other end shapes, suitable for different purposes can be made with these methods, provided that the helix is formed via a helical deformation arrangement.

[0055] Figure 6A shows a hollow extruded dowel type connector where the core is cylindrical (36). The perform member is pre-stamped prior to helical deformation with a swept angle point (18), which deforms a neck (21) bevel onto the cylindrical core (36).

[0056] Figure 6B shows the effect of point profile on the substrate material in terms of the compaction pressure waves (52) created and shown by layers of black curved lines. The upper part of the drawing shows how the spike like point profile creates a compaction pressure wave (52) that resembles the wave pattern on the bow of a boat creating an over widened path of disturbance. In terms of fastening principles this means the substrate material abutting the core of the fastening and central helical interlock is compaction failed and weakened. The lower part of the drawing shows a blunt end nose (29) profile, which creates far less compaction (52) forces, which themselves tend to be more forward focussed within a closer core path. The fins on the swept angle (18) create a smooth entry passage and positive grip.

[0057] Figure 6C shows a connector driven through a timber element on the right, in and on into an aerated concrete block (12) on the left. It will be seen that the spike like profile point has caused the timber fibres to drag and slither apart and the aerated concrete to compact and crush substantively around the core shown by darkened shading.

[0058] Figure 7 shows one arrangement by which serrations can be applied to the faces of the ribs (3), by means of grooved rollers (60). Rolled serrations could be applied to any surface of the section providing an additional withdrawal grip to complement the helical interlock.

[0059] Figure 8 shows the benefits regarding torsional surface areas (38) and smooth mating of profile geometries with well radiused forms for the fins (2) and ribs

(3).

[0060] Figure 9 shows an arrangement by which the tubular helical sections, as shown in Figure 1 G, can be processed into conically pointed sections for uses such as plugs and dowels used in lightweight building materials. The helical deformed section, with an exact conforming helical pitch, is fed through a precisely mating guide block (23) that firmly restrains the section as orbiting bevelled milling cutters (55) form a conical neck on the tubular section.

[0061] Figure 10A shows how a wire, that is not in accordance with the invention, from being deformed with an open helix (35) can be used with lower strength materials, such as mortar (49) and grouts (50) in the confined application of laid and raked out mortar beds (46). The mortar (49) or grout (50) can flow (45) easily around the open helical form providing a reliable helical wave interlock (44) where the end use of alternative axial finned profiles may otherwise cause air pocket voids.

[0062] The helical wave (43) provides an optimum balance of interlock (44) between the grout (50) or mortar (49), the strength providing a geometric mechanical balance. The helical form has a natural geometric elastic profile enabling the composite grout/mortar reinforcement layer to flex under high tensile (47) and compressive (48) loads. Such loads are present in seismic stresses and the composite is capable of full recovery after considerable movement. Such uniquely manufactured reinforcement will provide the uniformity of pitch to fully flex and recover.

[0063] Figure 10B shows an isometric view of the open helical form that is not part of the invention (35) that demonstrates the extent of the helical wave interlock (44) shown as an circumscribed cylinder. Also demonstrated is the dramatic extent to which the reinforcement rods nestle and interlock, enabling efficient overlap jointing.

[0064] Figure 10C shows a cross sectional view that is not part of the invention that reveals the extent of the helical wave interlock (44).

[0065] Figure 11A shows a triangular helical section where the helix is open. That is to say it is non axial about its centre though there is common axial core material (1). This form of helix, which is vaguely similar to an elongated cork screw, can only be produced by such a helical deformation arrangement as it has no axial line of torsional symmetry. Both this and the section in Figure 12 have a high interlocking characteristic into the materials they connect due to accentuated gyrational form ideal for weaker substrate reinforcement.

[0066] Figure 11B shows a means of cross connecting reinforcement sections via a substantive helical interlock, retained by a simple clip arrangement (51) shown as a dotted line.

[0067] Figures 12A and 12B show the same arrangement as Figure 11A where the section is of a circular form, and is therefore not part of the invention.

[0068] Figure 13 shows, by way of comparison, a conventional reinforcing rod which has considerable cross

section mass in relation to its effective circumscribed diameter (35) which provides little interlock bond especially in relation to weaker substrates.

[0069] Figure 14 shows a connector with end tabs for use in securing a composite layer (17) to an aerated concrete block wall (12). With this application of the helical connector a metal load-spreading press on clip or washer-like retaining head is provided. This washer could also be made of injection moulded plastics materials. The tabbed ends (25) will lock against the surface of the washer-like head when it is fully driven in through a simple key-hole slot (27), corresponding with the sectional shape of the fixing. When the tabs (25) at the end are hit by a driving tool, they will be bent down to lie in the same plane as the surface of the washer-like retaining head, so that they will effectively clamp it in position. It will be appreciated that, if the leading end of a fixing (24) with a constant helical pitch, starts to be driven through a tightly fitting key-hole slot (27), the fixing will immediately be rotated at the correct rate to suit the seatings or "threads" to be cut in the soft materials as the helical form penetrates further.

[0070] Figure 15 shows a collated belt of fixings lying in a cylindrical container (34) with an outlet duct. A fixing (30) is in a position to be driven into a timber component joint or into layers of composite building materials to be secured together by a nailing machine. At the centre of the cylindrical container (34) is a spool (33) around which the band of collated fixings has been wrapped and this can be rotated (as indicated by arrows) to assist in discharging the fixings.

[0071] Figure 16A shows an end section drawn through a reinforced concrete member, such as an I-beam or a mullion.. There are two pairs of longitudinal helical reinforcement wires (40), one pair at the top and one pair at the bottom. The upper and lower pairs of longitudinal reinforcement wires are connected together by means of transverse wires (41) of the same configuration. It will be seen that the transverse wires (41) are effectively sandwiched between the pairs of longitudinal wires (40) so that their helical fins securely lock together and can be readily wired or clipped accurately together at their intersections. Once the concrete (42) has set, such structural connections will be absolutely secure. It will be seen by looking at the drawings that regularity of helical pitch is essential for these purposes in setting accurate pre-determined pitch increment modules.

[0072] Figure 16B shows a plan view of the reinforcement cage

[0073] Figure 17A shows the helical acceleration path of a typical helical deformation arrangement (22) through the forty plus angular increments represented by a vertical distance of a half pitch (53), the helical distance of a 180° rotation. To scale, this arrangement would reveal a full pitch rotation of approximately 50mm to 60mm. The lower part of the drawing shows a minimum set of nine helical broaching tools (54) required to rough out the forty plus deflection nodes. These tools correspond, in stages,

to the shape of the internal profile of the deforming arrangement. At the inlet side, on the left, there would be required a small number of straighter tools.

[0074] Figure 17B shows the other two sets of angular paths (56, 57) that have to be incorporated within the overall three-dimensional angle of the internal path of the helical deformation arrangement (22). The upper right drawing shows the inclining angle (57) at the radial extremes, which have to be accommodated as the perform member is forced through the deformation arrangement (22) in the direction of the central arrow, indicating the central core axis. This inclining angle (57) is a result of the increase in the helix angle when induced outwardly from the core (1). The effect is shown on the lower diagram where the fins (2), flanges or ridges are sectioned out progressively from left to right to reveal the helical angles (56) at radial increments.

[0075] According to a preferred embodiment, the invention provides a helically profiled connecting device or reinforcement in the form of a preformed wire, rod or hollow extrusion with a common axial core material cross section of two-fifths or less of the circumscribed cross sectional area, that being deformed via means of a progressive acceleration of helical compound angles forming a distributed twisting path of surface deflection, the tightness of helical pitch being one full 360° rotation within a distance of five and a half circumscribed profile diameters or less, the accuracy of pitch being plus or minus 0.5% along the axial measurements on any given probate pitch.

[0076] Advantageously, the performed wire, rod or hollow extrusion is stamped substantially through prior to helical deformation as described above, the stamped profile providing a swept angle of between 20° and 40° inclusive, and a flat nose end corresponding to between 90% and 40% of the common axial core cross section, with the entire stamped edge falling inside the original helical profile path after subsequent deformation.

[0077] The wire, rod or hollow extrusion may stamped in such a manner that the stamped profile provides trailing and projecting tabs of material upon the fin material ends, these subsequently folding over flat when hammered. The wire, rod or hollow extrusion may contain two or three major fins leading from a central core.

[0078] Preferably, the invention also provides a method of producing helically deformed sections of a highly profiled structure, through surface deflection, upon an accelerating path, incorporating the multitude of helical compound angles. Such a path profile enables the smooth passage of non-uniform sections whilst holding it to an accuracy of helical pitch of one half of one percent when measured along the central axis.

Claims

1. A driven connector having a constant helical configuration comprising;

a wire body having an axial core (1) having a cross section comprising two-fifths or less of the circumscribed cross sectional area of the wire profile,

two or three major radial fins (2) extending helically from the core (1), and

a load spreading pressed clip or washer-like retaining head for securing and clamping construction layers together, **characterized in that** the accuracy of the pitch of the helical projections varies by no more than 0.5% from any given pitch along the axis of the device.

2. A connector according to claim 1, in which the helical pitch includes at least one full 360° rotation within an axial distance of five and a half circumscribed profile diameters.

3. A connector according to claim 1 or 2, in which the wire has been rolled through grooved rolls to form the finned profile.

4. A connector according to any one of the preceding claims, in which the wire profile has radiused faces formed at the root material of the fins.

5. A connector according to any one of the preceding claims, in which the helix extends substantially along the whole of the length of the connector.

6. A connector according to any one of the preceding claims, in which the retaining head or clip is preformed with a hole or a slot (27).

7. A connector according to claim 6, in which the hole or slot (27) corresponds with the sectional shape of the wire profile.

8. A connector according to claim 6 or 7, in which the wire profile is arranged such that, in use, the connector is immediately rotated when its leading end is driven in through the hole or slot (27).

9. A connector according to claim 8, in which the rotational relationship between the wire and the retaining head or clip rotates the wire at the correct rate to suit the helical seating or "threads" to be cut in the building material as the helical form penetrates further.

10. A connector according to any one of the preceding claims, in which the hole or slot (27) and connector are arranged such that the fit between them is tight.

11. A connector according to any one of the preceding claims, in which the retaining head or clip is metallic.

12. A connector according to any one of claims 1 to 10, in which the retaining head or clip is plastic.

13. A connector according to any one of the preceding claims, in which the connector includes locking means (25) for fixing the position of the retaining head or clip.
14. A connector according to claim 13, wherein the locking means (25) is arranged to radially engage the retaining head or clip.
15. A connector according to any one of the preceding claims, in which the connector includes tabbed ends (25).
16. A connector according to any one of claims 13 to 15, wherein the locking means (25) is deformable to fix the position of the retaining head or clip.
17. A connector according to any one of the preceding claims, wherein the wire body includes first and second major radial fins (2) and first and second rib-like projections (3) located between the major radial fins.
18. A method for securing first and second construction layers (12,17) together with a connector according to any of the preceding claims, wherein the method includes driving the connector into the first and second construction layers (12,17) and clamping the second construction layer (17) with the washer-like retaining head, and **characterized in that** the accuracy of the pitch of the helical projections varies by no more than 0.5% from any given pitch along the axis of the connector device.

Patentansprüche

1. Angetriebenes Verbindungsstück mit beständiger spiralförmiger Gestaltung, umfassend:
- einen Drahtkörper mit einem axialen Kern (1) mit einem Querschnitt, der zwei Fünftel oder weniger der umschriebenen Querschnittsfläche des Drahtprofils umfasst, zwei oder drei radiale Hauptgrate (2), die spiralförmig von dem Kern (1) verlaufen, und ein lastverteilender Presshalter oder unterlegscheibenartiger Haltekopf zum Befestigen und Klammern von Bauschichten aneinander, **dadurch gekennzeichnet, dass** die Genauigkeit der Steigung der spiralförmigen Vorsprünge um nicht mehr als 0,5% von jeglicher vorgegebenen Steigung entlang der Achse der Vorrichtung abweicht.
2. Verbindungsstück nach Anspruch 1, wobei die Spiralsteigung zumindest eine volle Drehung um 360° innerhalb eines Axialabstands von 5½ umschriebenen Profildurchmessern beinhaltet.

3. Verbindungsstück nach einem der Ansprüche 1 oder 2, wobei der Draht zum Ausbilden des Gratprofils durch genutete Walzen gerollt wurde.
4. Verbindungsstück nach einem der vorhergehenden Ansprüche, wobei das Drahtprofil gerundete Seitenflächen am Wurzelmaterial der Grate aufweist.
5. Verbindungsstück nach einem der vorhergehenden Ansprüche, wobei die Spirale im Wesentlichen entlang der gesamten Länge des Verbindungsstücks verläuft.
6. Verbindungsstück nach einem der vorhergehenden Ansprüche, wobei der Haltekopf oder Halter mit einem Loch oder einem Schlitz (27) vorgeformt ist.
7. Verbindungsstück nach Anspruch 6, wobei das Loch oder der Schlitz (27) der Schnittform des Drahtprofils entspricht.
8. Verbindungsstück nach einem der Ansprüche 6 oder 7, wobei das Drahtprofil derart angeordnet ist, dass im Gebrauch das Verbindungsstück sofort gedreht ist, wenn sein Vorderende durch das Loch oder den Schlitz (27) eingetrieben ist.
9. Verbindungsstück nach Anspruch 8, wobei die Drehbeziehung zwischen dem Draht und dem Haltekopf oder Halter den Draht im korrekten Verhältnis dreht, das dem spiralförmigen Sitz oder den "Windungen" zweckdienlich ist, die in das Baumaterial geschnitten werden sollen, wenn die Spiralförmigkeit weiter durchdringt.
10. Verbindungsstück nach einem der vorhergehenden Ansprüche, wobei das Loch oder der Schlitz (27) und das Verbindungsstück derart angeordnet sind, dass eine feste Passung zwischen ihnen besteht.
11. Verbindungsstück nach einem der vorhergehenden Ansprüche, wobei der Haltekopf oder Halter aus Metall ist.
12. Verbindungsstück nach einem der Ansprüche 1 bis 10, wobei der Haltekopf oder Halter aus Kunststoff ist.
13. Verbindungsstück nach einem der vorhergehenden Ansprüche, wobei das Verbindungsstück Spermmittel (25) zum Fixieren der Position des Haltekopfs oder Halters beinhaltet.
14. Verbindungsstück nach Anspruch 13, wobei das Spermmittel (25) zur radialen Ineingriffnahme des Haltekopfs oder Halters angeordnet ist.
15. Verbindungsstück nach einem der vorhergehenden

Ansprüche, wobei das Verbindungsstück gelappte Enden (25) beinhaltet.

16. Verbindungsstück nach einem der Ansprüche 13 bis 15, wobei das Sperrmittel (25) zum Fixieren der Position des Haltekopfs oder Halters verformbar ist.
17. Verbindungsstück nach einem der vorhergehenden Ansprüche, wobei der Drahtkörper erste und zweite radiale Hauptgrate (2) und erste und zweite rippenartige Vorsprünge (3) beinhaltet, die sich zwischen den radialen Hauptgraten befinden.
18. Verfahren zum aneinander Befestigen erster und zweiter Bauschichten (12, 17) mit einem Verbindungsstück nach einem der vorhergehenden Ansprüche, wobei das Verfahren das Treiben des Verbindungsstücks in die ersten und zweiten Bauschichten (12, 17) und Verklammern der zweiten Bauschicht (17) mit dem unterlegscheibenartigen Haltekopf beinhaltet und **dadurch**

Revendications

1. Connecteur inséré possédant une configuration hélicoïdale constante, et comprenant :
- un corps de câble comportant un noyau axial (1) possédant une section transversale comprenant deux cinquièmes ou moins de la surface de la section transversale circonscrite du profil du câble ;
 - deux ou trois ailettes radiales principales (2) s'étendant hélicoïdalement depuis le noyau (1) ;
 - et
 - un clip pressé à étalement de charge ou une tête de retenue de type rondelle pour fixer et pincer ensemble des couches de construction ;
- caractérisé en ce que** la précision du pas des protubérances hélicoïdales ne varie pas de plus de 0,5 % depuis un quelconque pas donné le long de l'axe du dispositif.
2. Connecteur selon la revendication 1, dans lequel le pas hélicoïdal comprend au moins une rotation complète de 360° dans une distance axiale représentant cinq fois et demi le diamètre du profil circonscrit.
3. Connecteur selon la revendication 1 ou 2, dans lequel le câble a été laminé entre des cylindres comportant des gorges afin de former le profil à ailettes.
4. Connecteur selon l'une quelconque des revendications précédentes, dans lequel le profil du câble possède des faces roulées formées au niveau du matériau définissant la racine des ailettes.
5. Connecteur selon l'une quelconque des revendications précédentes, dans lequel l'hélice s'étend essentiellement sur toute la longueur du connecteur.
6. Connecteur selon l'une quelconque des revendications précédentes, dans lequel la tête de retenue ou le clip sont préformés de manière à comporter un trou ou une fente (27).
7. Connecteur selon la revendication 6, dans lequel le trou ou la fente (27) correspond à la forme de la section du profil de câble.
8. Connecteur selon la revendication 6 ou 7, dans lequel le profil de câble est disposé de sorte que, lors de l'utilisation, le connecteur est immédiatement entraîné en rotation lorsque son extrémité avant est entraînée à travers le trou ou la fente (27).
9. Connecteur selon la revendication 8, dans lequel la relation de rotation entre le câble et la tête de retenue ou le clip fait tourner le câble à la vitesse correcte correspondant à la portée hélicoïdale ou aux filetages hélicoïdaux devant être taillés dans le matériau de construction à mesure que la forme hélicoïdale pénètre plus avant.
10. Connecteur selon l'une quelconque des revendications précédentes, dans lequel le trou ou la fente (27) et le connecteur sont disposés de sorte que leur ajustement soit étroit.
11. Connecteur selon l'une quelconque des revendications précédentes, dans lequel la tête de retenue ou le clip sont métalliques.
12. Connecteur selon l'une quelconque des revendications 1 à 10, dans lequel la tête de retenue ou clip sont en plastique.
13. Connecteur selon l'une quelconque des revendications précédentes, dans lequel le connecteur comprend un moyen de verrouillage (25) permettant de fixer la position de la tête de retenue ou clip.
14. Connecteur selon la revendication 13, dans lequel le moyen de verrouillage (25) est conçu pour engager radialement la tête de retenue ou clip.
15. Connecteur selon l'une quelconque des revendications précédentes, dans lequel le connecteur comprend des extrémités à languettes (25).
16. Connecteur selon l'une quelconque des revendications 13 à 15, dans lequel le moyen de verrouillage (25) est déformable de manière à fixer la position de la tête de retenue ou clip.

17. Connecteur selon l'une quelconque des revendications précédentes, dans lequel le corps du câble comprend des première et seconde ailettes radiales principales (2) et des première et seconde protubérances de type nervures (3) situées entre les ailettes radiales principales. 5

18. Procédé pour fixer l'une à l'autre des première et seconde couches de construction (12, 17) à l'aide d'un connecteur selon l'une quelconque des revendications précédentes, lequel procédé consiste à insérer le connecteur dans les première et seconde couches de construction (12, 17) et à pincer la seconde couche de construction (17) avec la tête de retenue de type rondelle, **caractérisé en ce que** la précision du pas des protubérances hélicoïdales ne varie pas de plus de 0,5 % depuis un quelconque pas donné le long de l'axe du dispositif de connexion. 10
15

20

25

30

35

40

45

50

55

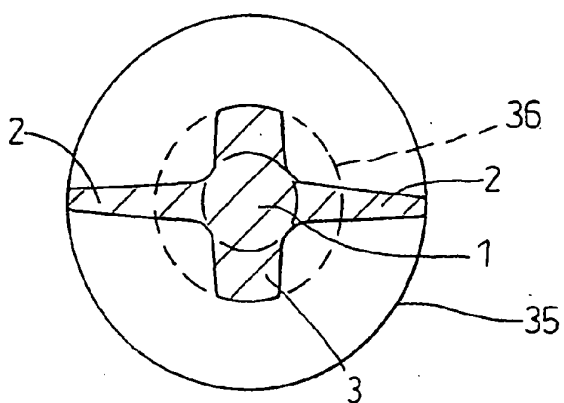

Fig. 1A

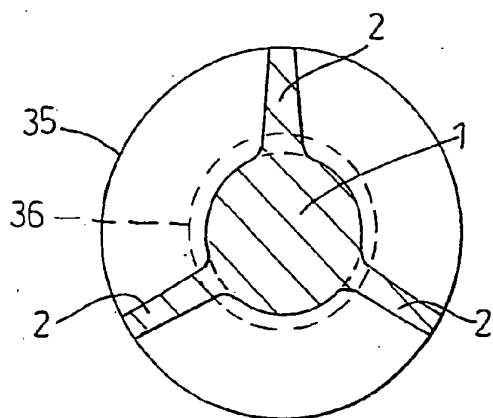

Fig. 1B

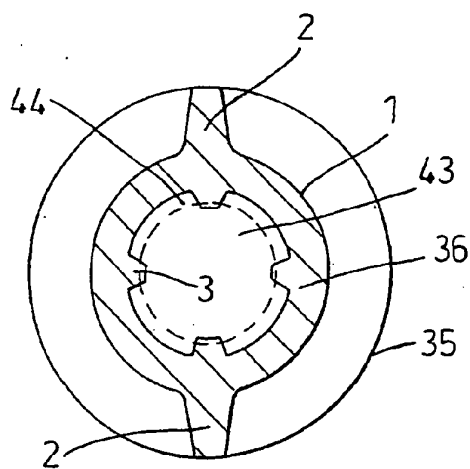

Fig. 1C

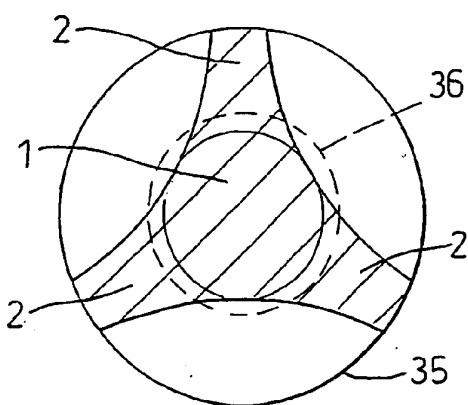

Fig. 1D

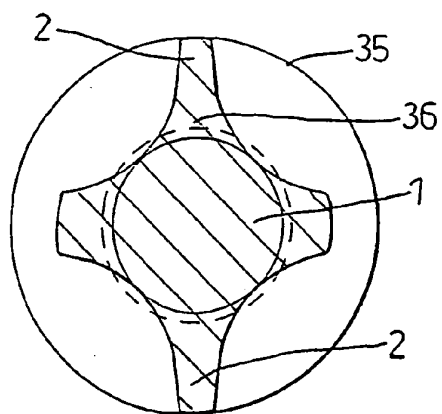

Fig. 1E

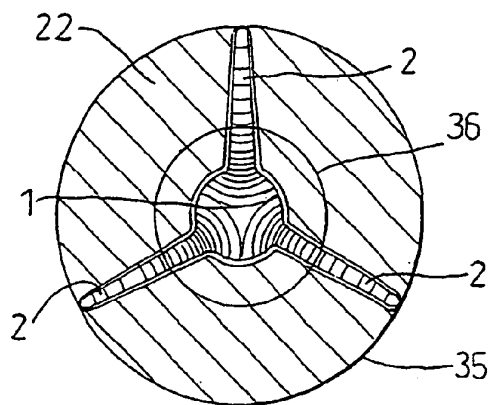

Fig. 1F

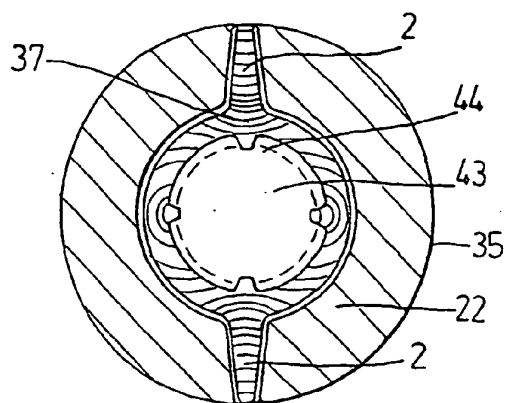

Fig. 1G

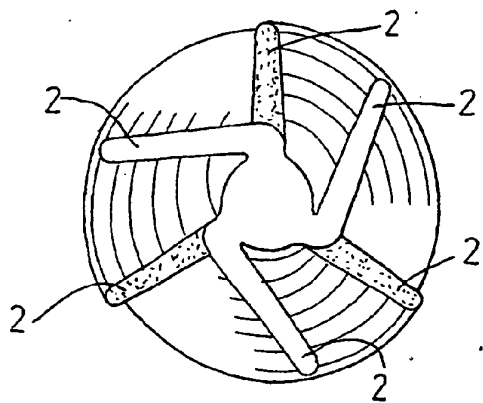

Fig. 1H

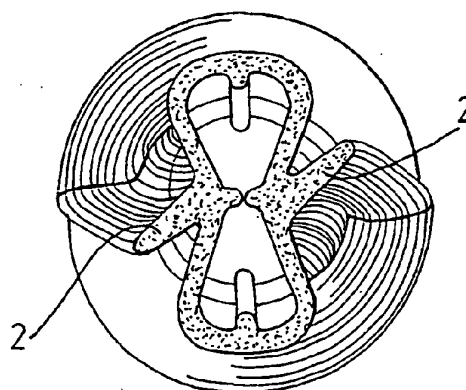

Fig. 1I

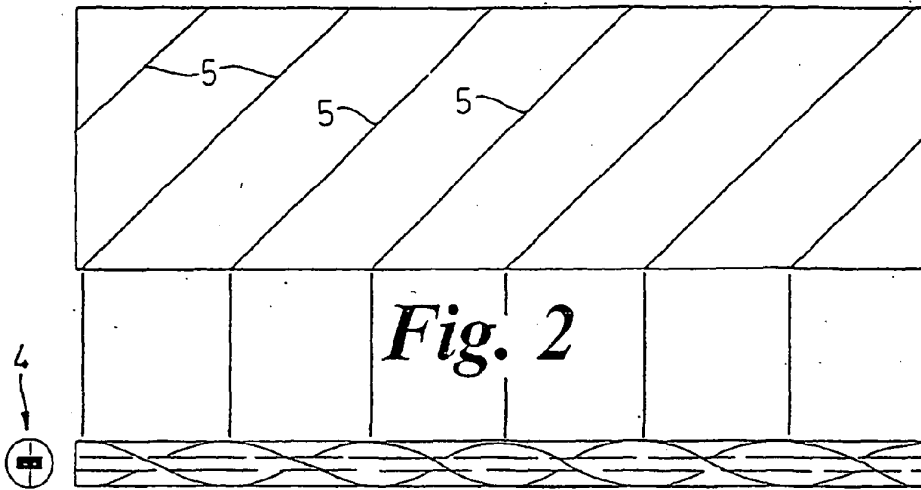

Fig. 2

Fig. 2A

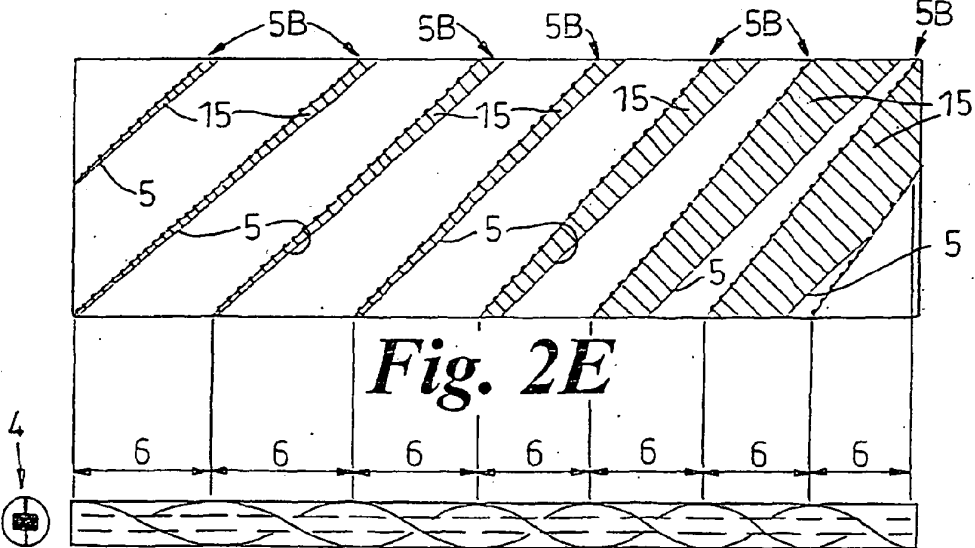

Fig. 2E

Fig. 2B



Fig. 2C

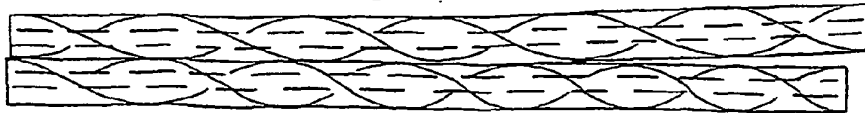

Fig. 2D

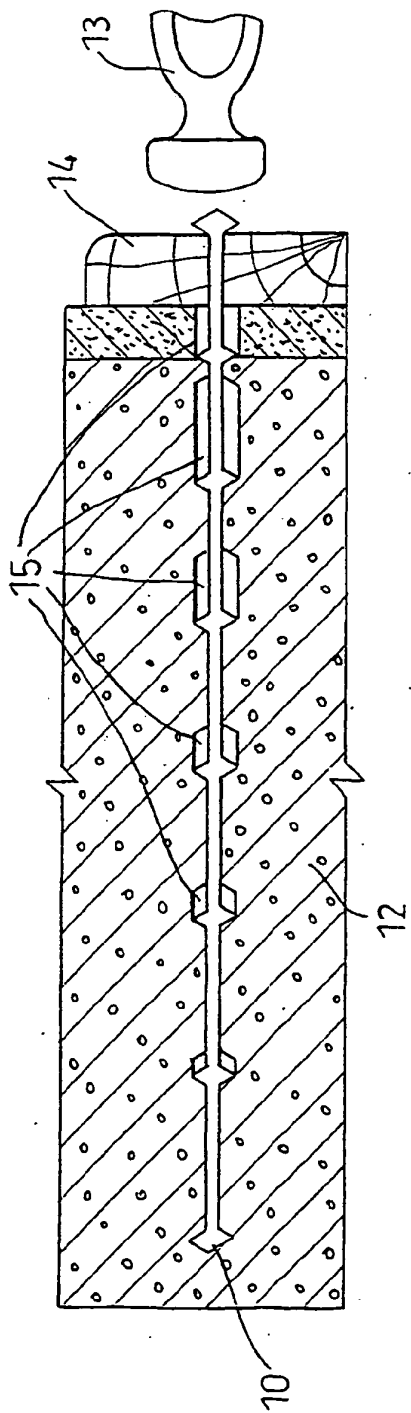

Fig. 3A

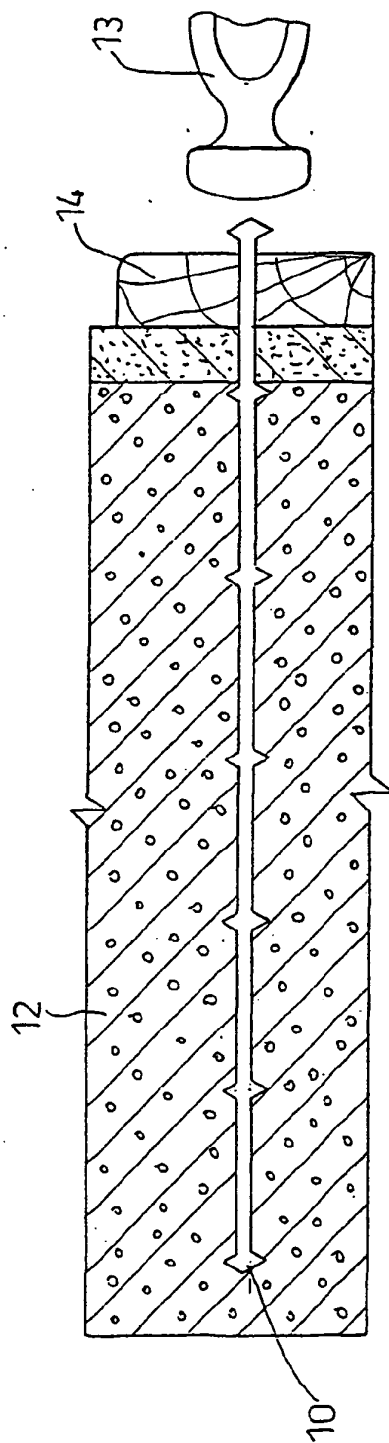

Fig. 3B

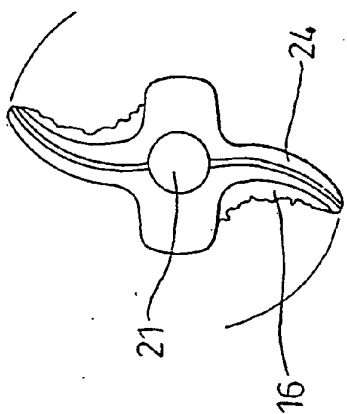

Fig. 4A

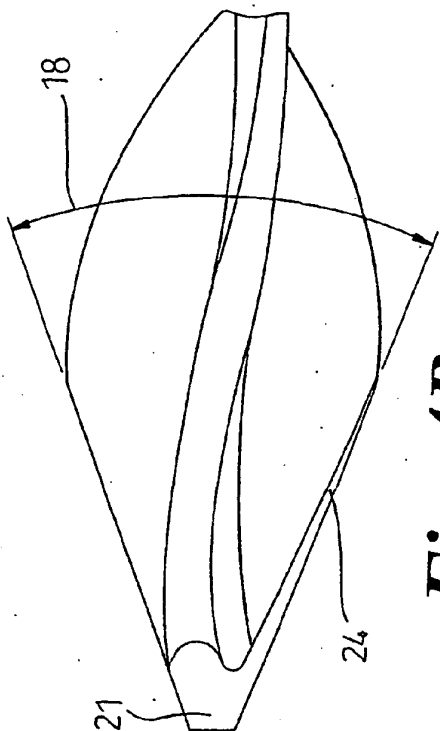

Fig. 4B

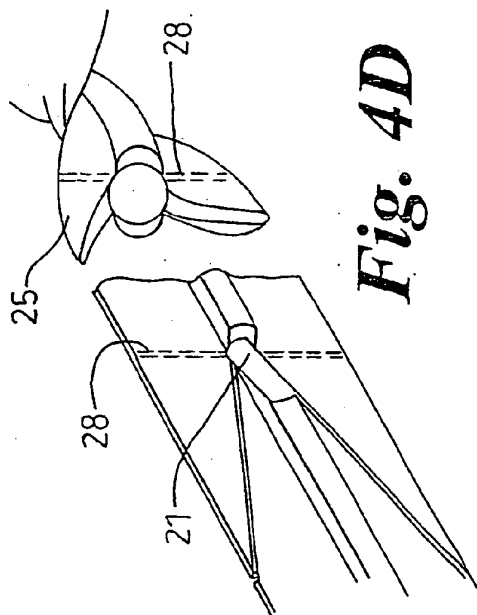

Fig. 4D

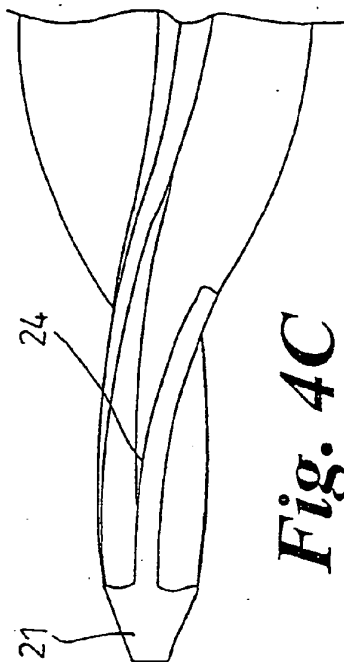

Fig. 4C

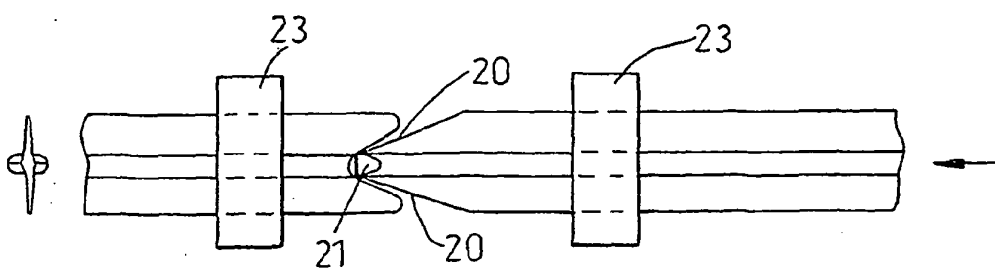

Fig. 5A

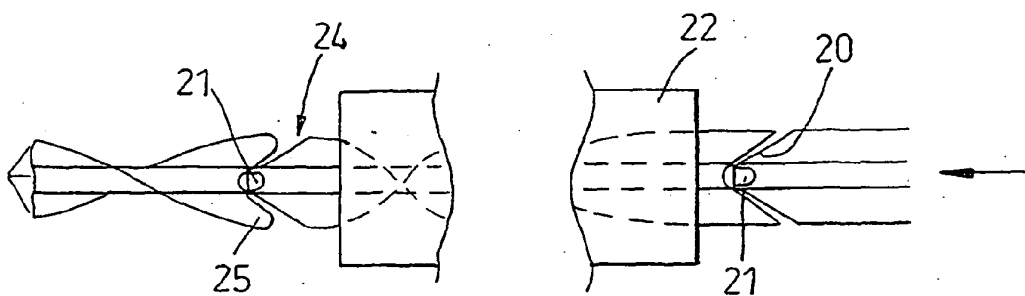

Fig. 5B

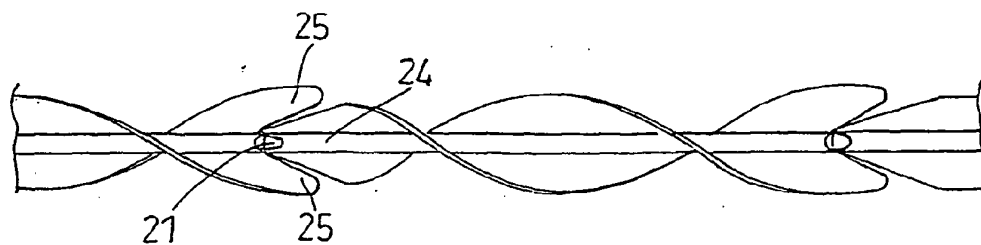

Fig. 5C

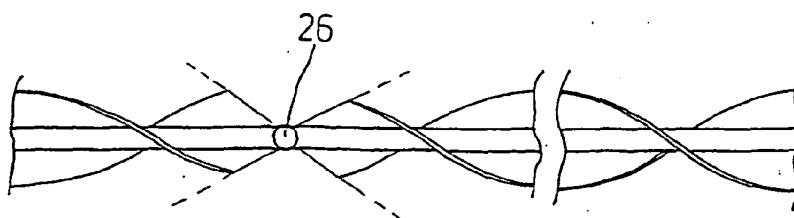

Fig. 5D

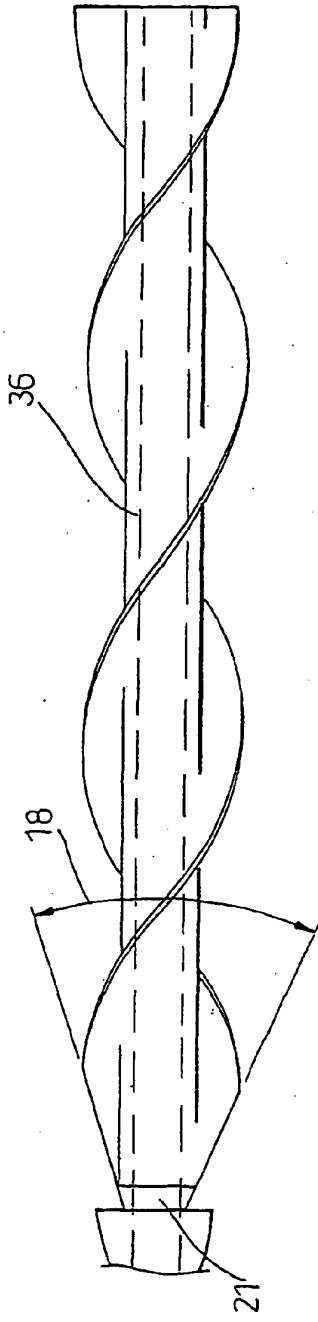

Fig. 6A

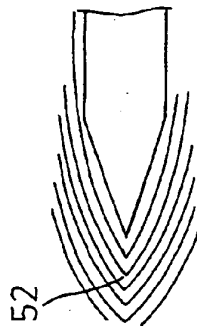

Fig. 6B

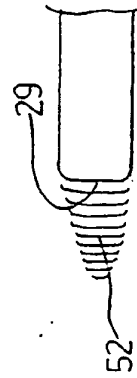

Fig. 6C

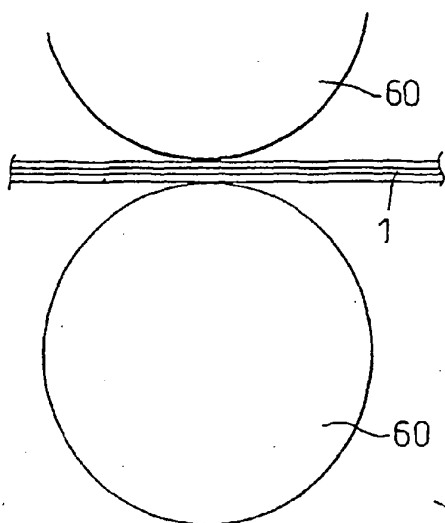

Fig. 7A

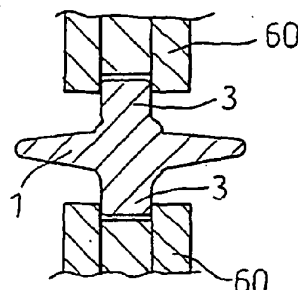

Fig. 7B

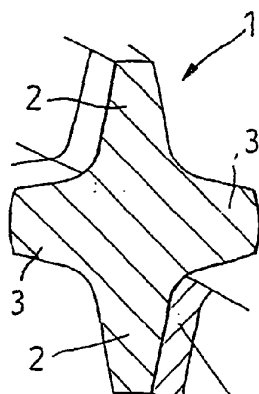

Fig. 8A

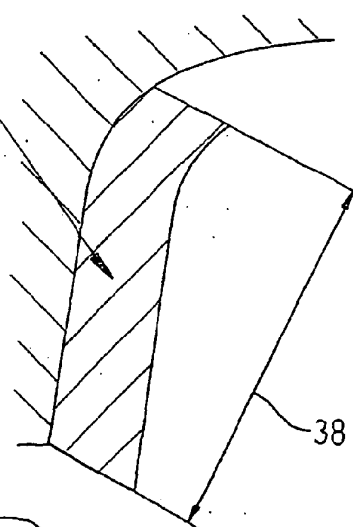

Fig. 8B

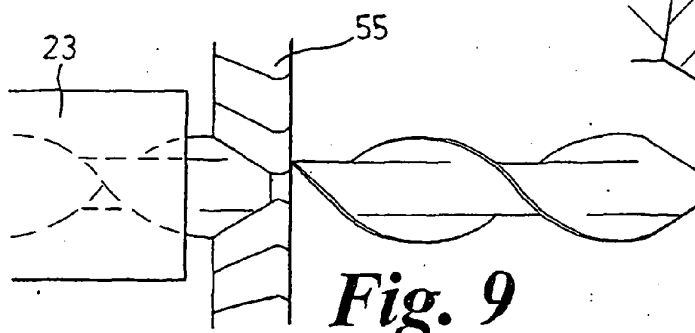

Fig. 9

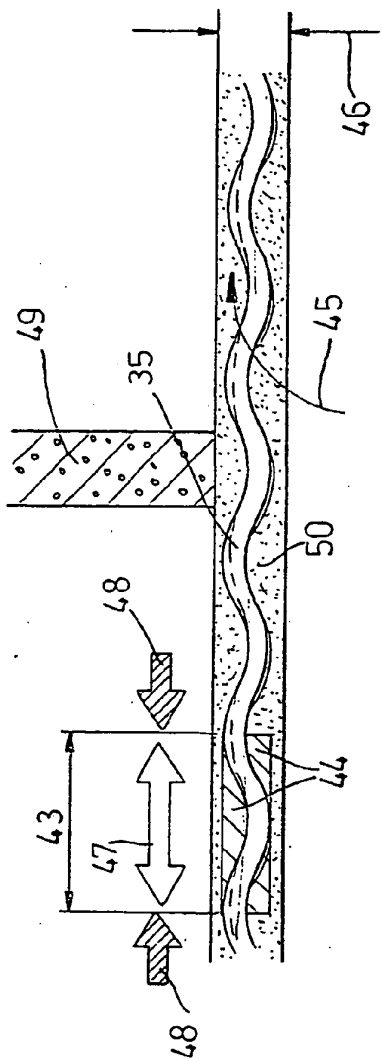

Fig. 10A

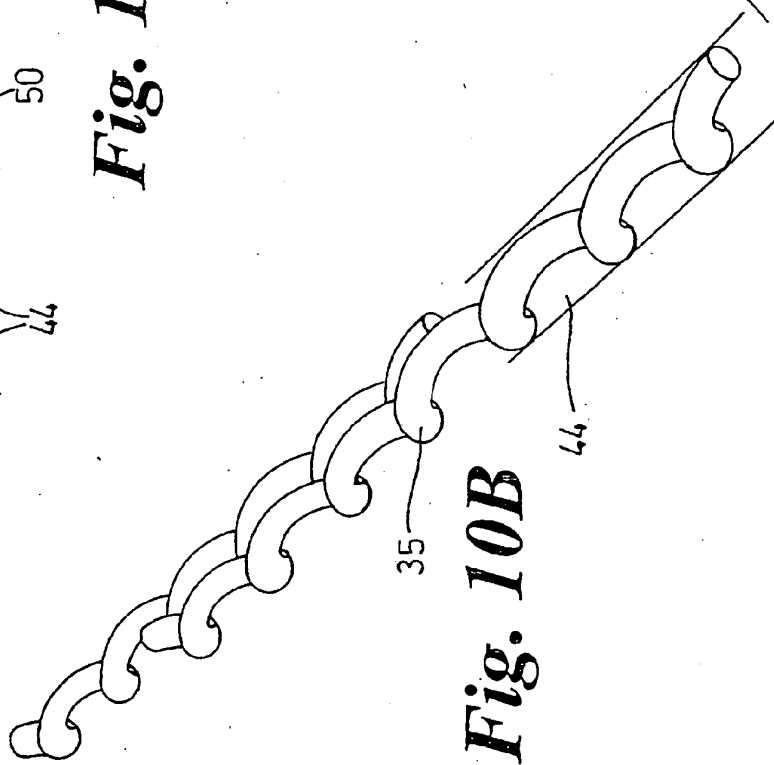

Fig. 10B

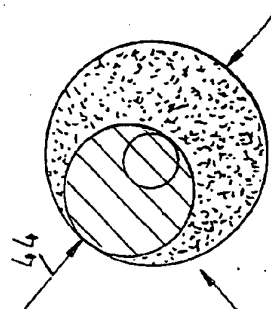

Fig. 10C

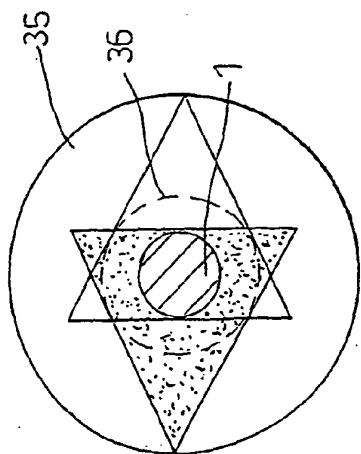

Fig. 11A

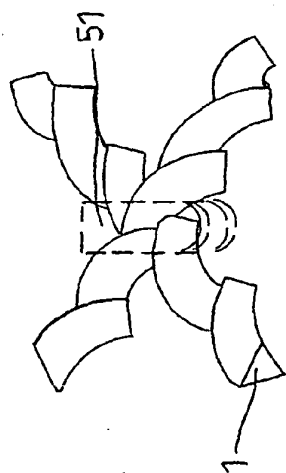

Fig. 11B

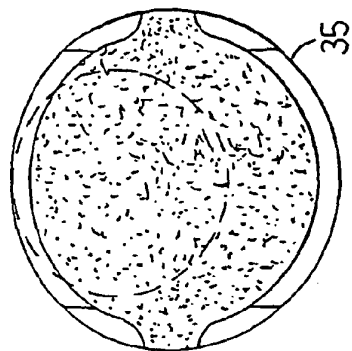

Fig. 13A

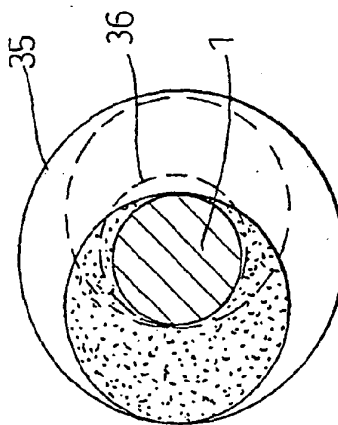

Fig. 12A

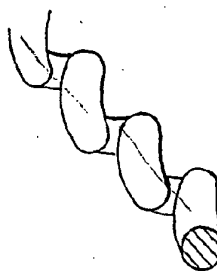

Fig. 12B

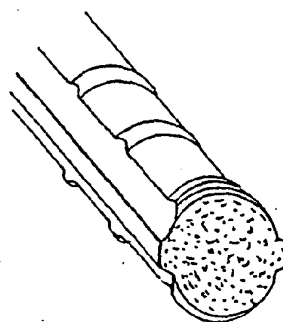

Fig. 13B

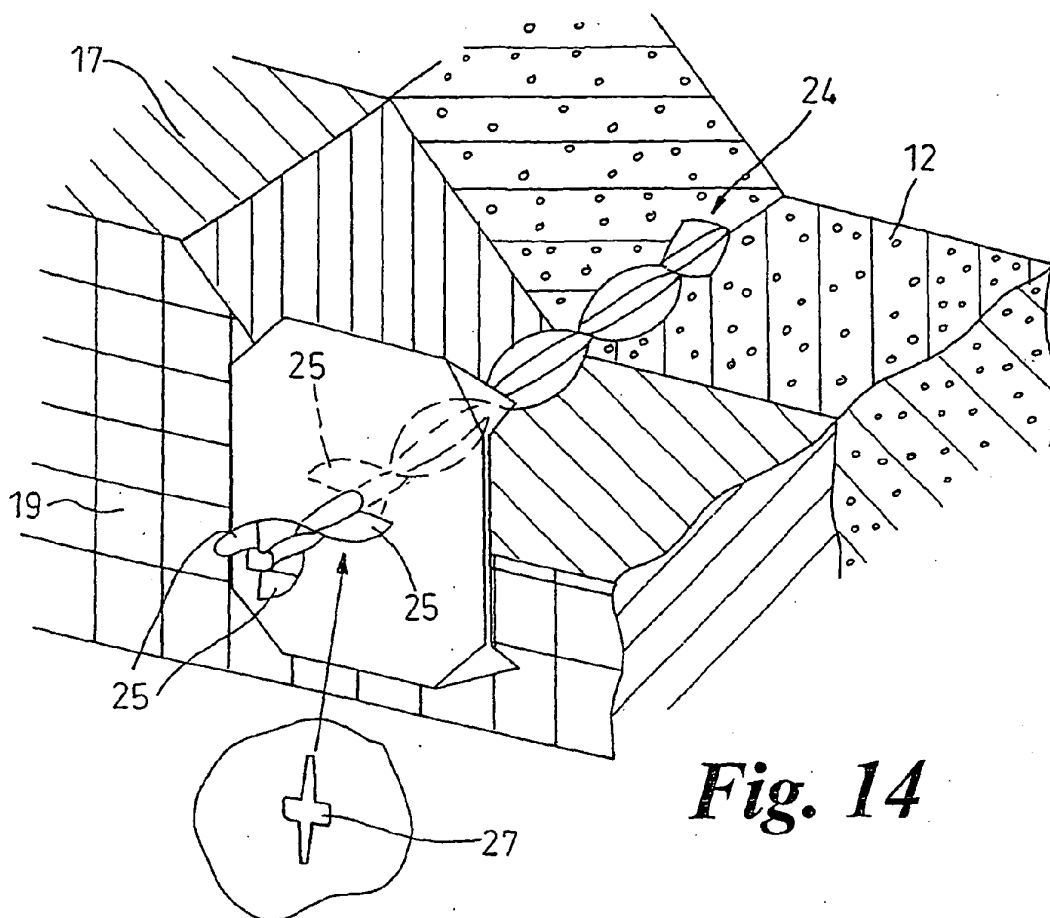

Fig. 14

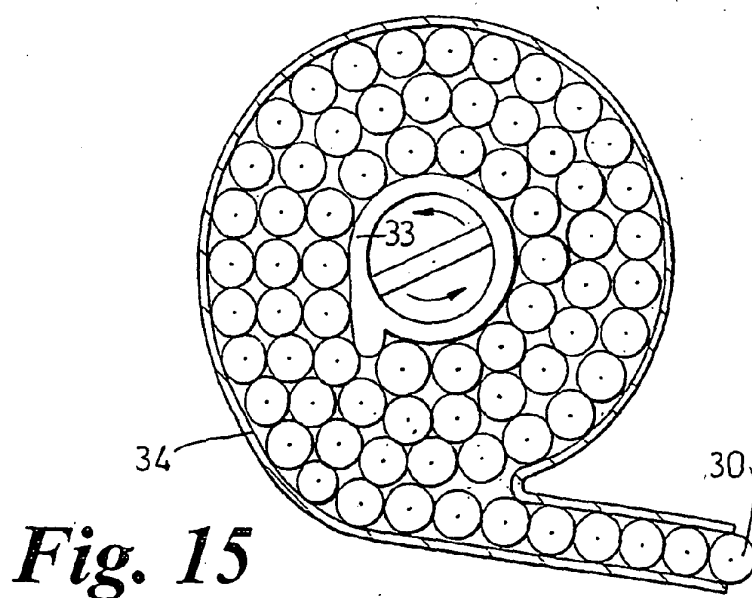

Fig. 15

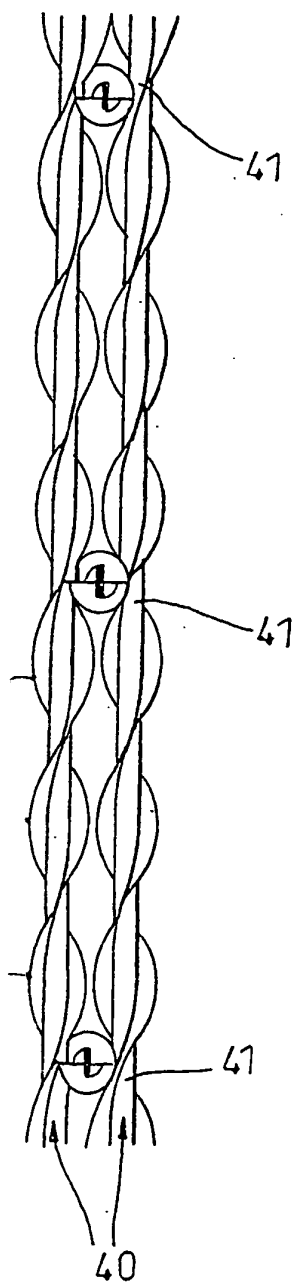
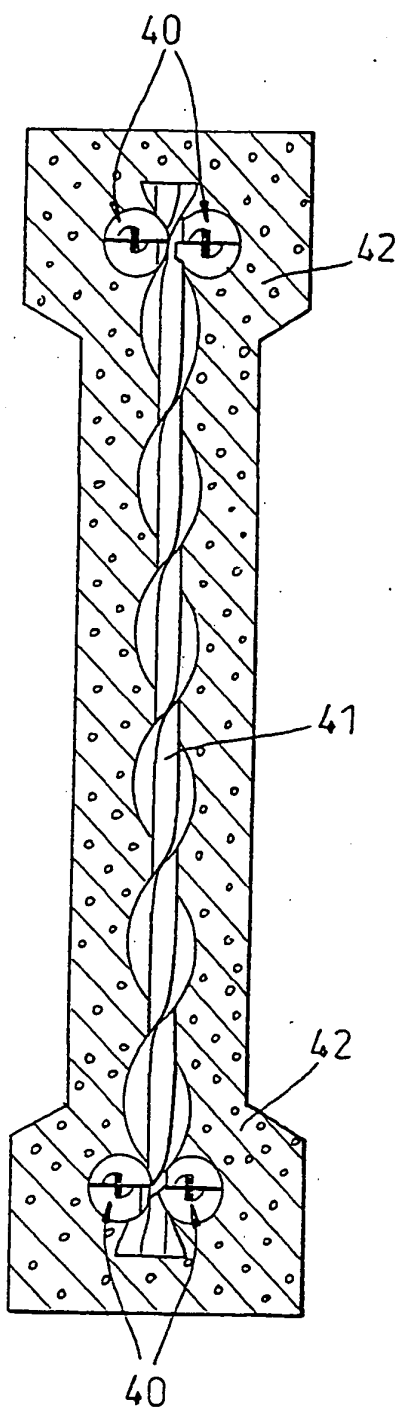

Fig. 16A

Fig. 16B

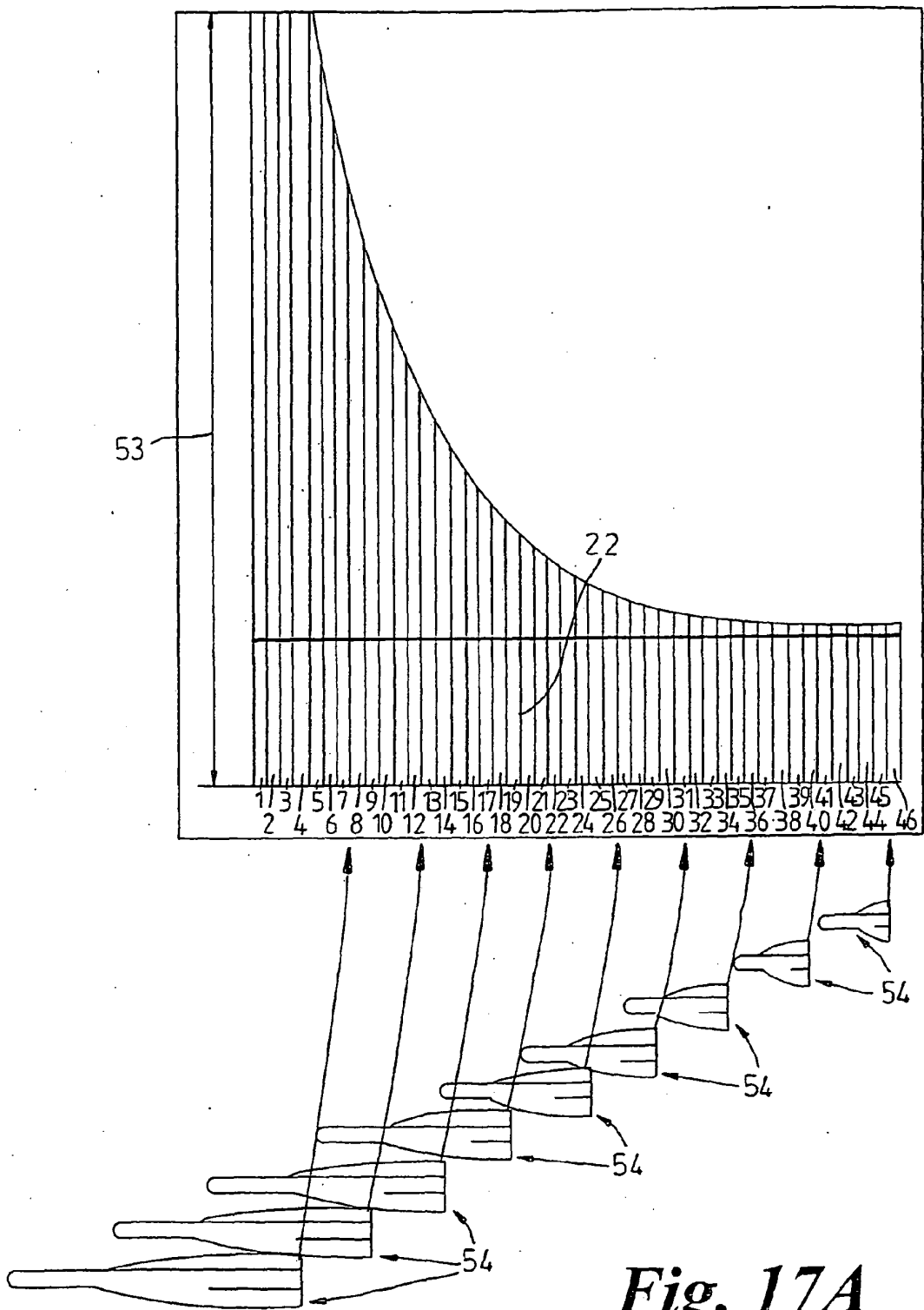

Fig. 17A

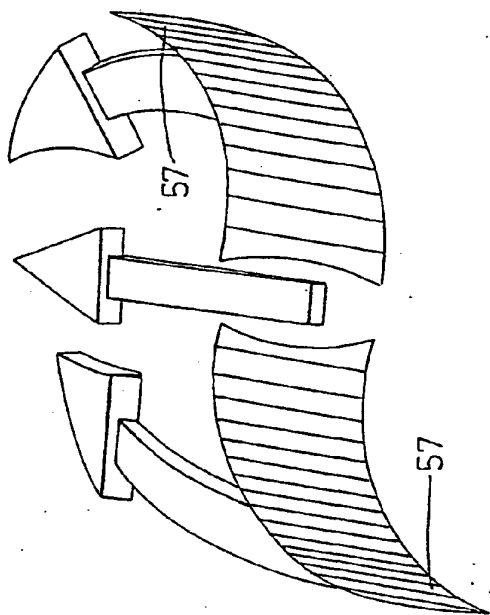
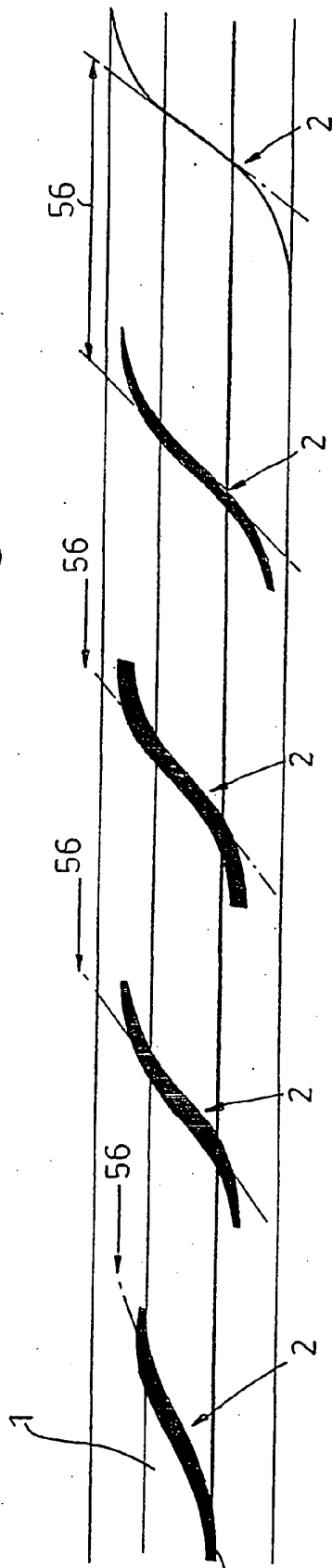

Fig. 17B



EP 1 710 372 B1

REFERENCES CITED IN THE DESCRIPTION

This list of references cited by the applicant is for the reader's convenience only. It does not form part of the European patent document. Even though great care has been taken in compiling the references, errors or omissions cannot be excluded and the EPO disclaims all liability in this regard.

Patent documents cited in the description

- EP 0494099 A [0001]
- GB 2262560 A [0001]
- EP 0171250 A [0001]
- US 4325657 A [0004]
- EP 150906 A [0028]
- GB 2107017 A [0028]